

This set does not contain body shell, tires and wheels. Please prepare them individually.
 Also, please prepare 4pcs of AA / LR6 batteries for transmitter.

※ **Please read before start running the car.** ※

● Attaching body mount seesaws.

Please follow instruction attached in the body shell set purchased separately.

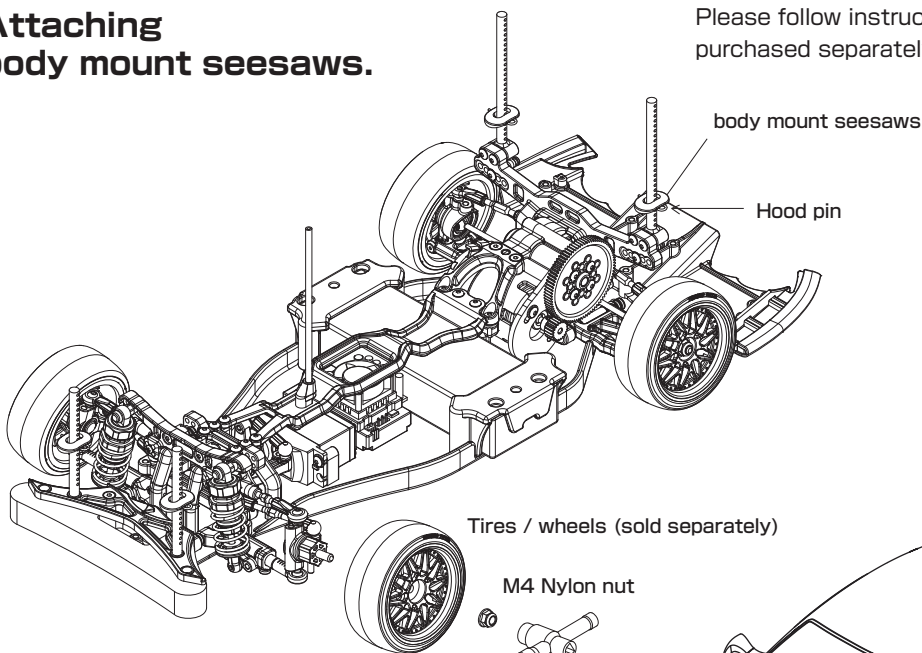

● Setting tires and wheels.

※When installing the wheel, be careful not to drop the pin that secures the brake disc wheel hub.

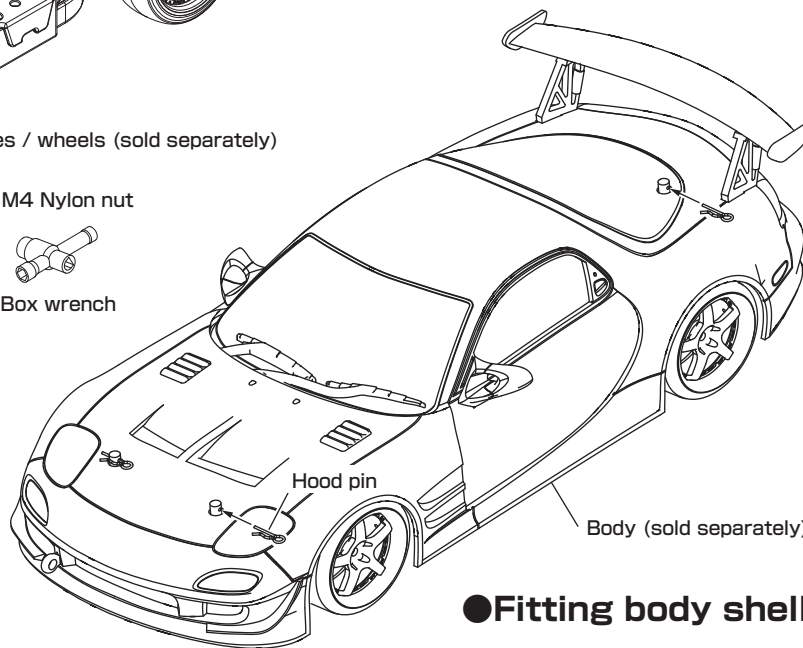

● Fitting body shell

Body will be fixed with hood pins.

※Cut unnecessary parts of the body post with nippers.

● Battery and AC quick chargers

Battery included in the set is 1400mAh Ni-cd type. Charge the battery with charger before running the car.

※For your safety, please follow the precautions for handling the charger and Ni-Cd battery.

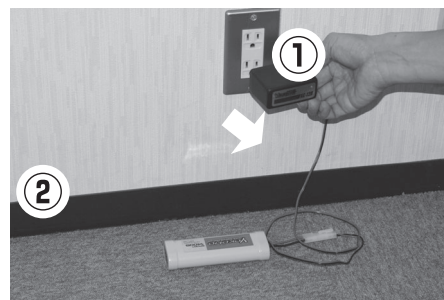
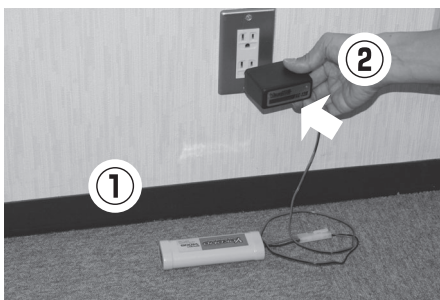

When charging the battery, connect the battery to quick charger, then plug the charger into an outlet. It will take about 70 minutes to fully charge the supplied battery.

When charging is completed, first unplug the charger, then remove the battery.

●How to use transmitter

First, insert four AA / LR6 batteries into the transmitter. When running the car, be sure to turn on the power switch of the transmitter first and then turn on the power of the car. If you don't follow this procedure, there are possibility that car will run out of control and is dangerous.

Check the steering and throttle neutrals before driving. Make sure that steering wheels are to run straight, and throttle position are in neutral that motor does not start moving when not operating.

※When turning on the switch on the car side, keep the tires away from the road surface. Since it might become very dangerous that car might run involuntarily when a neutral shift occurs.

When starting and ending the run, follow steps ① to ② below.

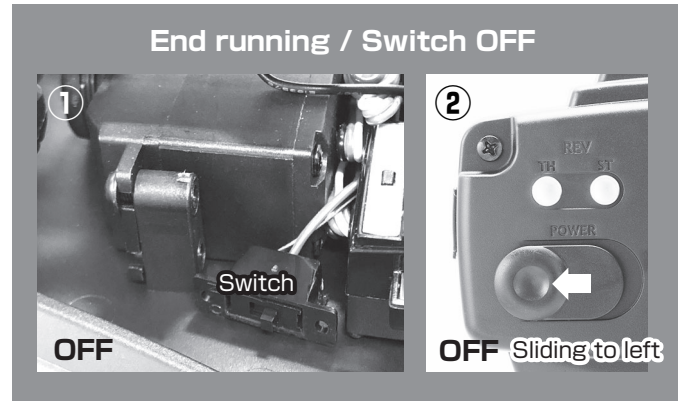
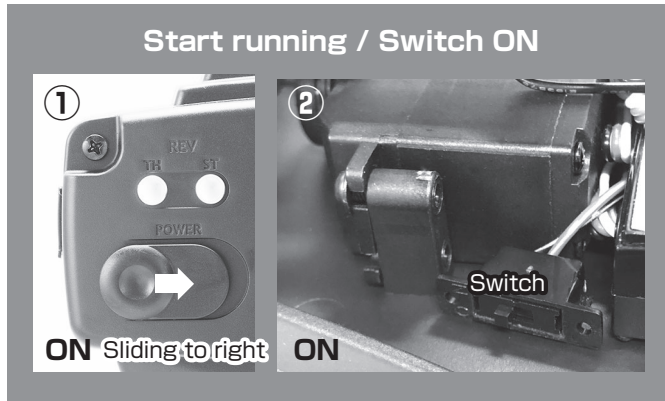

●Gyro Sensors

Initial Setting on switches

Switch 1 : Analog Switch 2 : Reverse Volume Rate : 50%

Wiring connection diagram and set, diagram of adjustment part

Use the plastic screwdriver included in the set to adjust the switch and sensitivity.

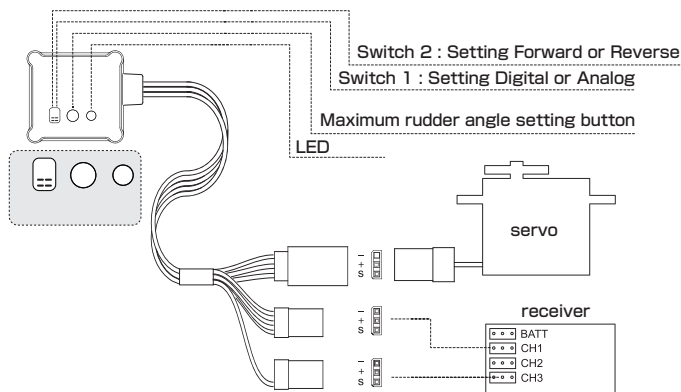

●Gyro need to be fixed with double sided tape in flat area of upper deck or main chassis.

●Switch 1 (Right side): There are two types of signals that the servo moves: analog and digital. The set at the time of purchase is in the digital mode used by many people. If the servo does not respond, set the switch up to make it analog.

●Switch 2 (Left Side) : Setting the operating direction of the servo with the gyro. The set at the time of purchase is reversed and is set on the switch. If try turning the steering wheel before driving and the servo does not move in the counter direction, set the switch 2 to the lower / forward rotation again.

Driving procedure and maximum rudder angle setting

- ① Place a bodyless car with a gyro on a flat table or ground.
 - ② If turning on the power without the body, the gyro LED will be blinking fast. This is a sign that detects gyro neutral and steering neutral. Do not move the vehicle body or steering wheel during detection.
 - ③ If the LED stops blinking and stays on, it is a sign that the neutral setting is completed.
 - ④ However, if the fast blinking of the LED does not change to lighting and then changes to slow blinking, it is a sign that the normal neutral setting has failed to complete, so start over again from ①.
 - ⑤ Turn the steering wheel to the right on the transmitter side, press the switch briefly at the point where it hits the steering stopper, the red-blue light blinks twice at high speed, then blue lights up, and red lights up slowly indicates that the setting has been saved.
 - ⑥ Next, as same with the right side, press the switch briefly at the point where it hits the stopper. The red-blue light blinks twice at high speed, and then the red-blue lights turn on at the same time, it indicates that the second setting has also been saved.
 - ⑦ The steering is set to neutral and the gyro endpoint setting is completed.
- *This product cannot be used if the 3rd channel of the transmitter is push button type.
- *When adjusting the endpoint, adjust it within the range where the load is not applied to the servo. Please note that when a load is applied to the servo, a load sound will be generated from the servo.

SPEED CONTROLLER

SCR-BR

Initial Settings are installed as
"※" marked on Mode Parameter table.



Yokomo Speed Controller (ESC) SCR-BR Instruction Manual

■ SPEC

- Input voltage: 7.2V to 8.4V (Ni-cd / Ni-MH), 7.4V (Li-Po), 6.6V (Li-Fe)
 - Number of Ni-cd / Ni-MH cells 6 to 7 (7.2V / 8.4V)
 - Number of Li-Po cells: 2 (7.4V)
 - Number of Li-Fe cells: 2 (6.6V)
- Output voltage: Forward continuous maximum current 70A Instantaneous maximum current 500A / 10 seconds, Reverse continuous maximum current 100A (FET specified)
 - Steady current (forward): 5 minutes / 70A, 30 seconds / 80A, 1 second / 106A
 - Steady current (backward): 5 minutes / 35A, 30 seconds / 40A, 1 second / 53A
- Maximum output current: 504w BEC 5V 1A (maximum 1.5A)
- Size / Weight: 3.4mm x 34.5mm x 27.5mm / 50g
- Available turns: 15 turns or more [\leq 7.2V (Ni-MH 6 cells)], 17 turns or more [8.4V (Ni-MH 7 cells)]
- Pulse frequency: 1KHz

■ Battery voltage automatic cutoff setting

Battery	Volt	7.2V	7.4V	6.6V
AUTO		Initial setting voltage × 70%		
Ni-cd / Ni-MH		5.4V	-	-
Li-PO		-	6.5V	-
Li-Fe		-	-	4.8V

※ Please set in the ESC setting.

■ ESC wiring diagram

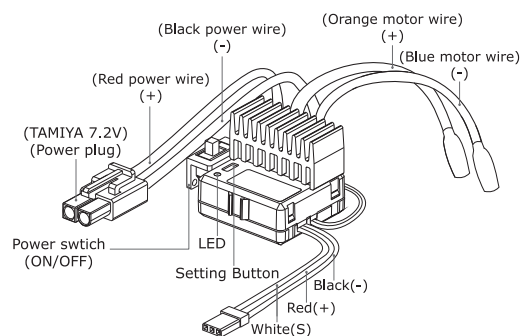

■ ESC Overheat protector

When the motor temperature reaches 98 °C (± 3-5 °C) ESC will intermittently repeats on and off.

※ In this case, stop driving immediately and turn off the ESC switch.

The receiver connector connects to CH2. The polarity matches Sanwa, KO and Futaba receivers. Check the polarity for other brands of receivers before plugging in.

■ Throttle Neutral setting



* Do not operate the throttle on the transmitter until the neutral setting is completed.

* Depending on the transmitter manufacturer, forward and reverse may be reversed when the neutral setting is made. In that case, change the slot reverse switch of the transmitter from normal to reverse setting.

	Neutral	Forward	Full Throttle	Brake	Full Brake	Reverse	Full Reverse
LED lamp	Yellow	Red blink	Red	Red slow blink	Red	Red slow blink	Red

■ Caution

- After driving, ESC is hot around heatsink and motor case, so don't touch it.
- Always use connectors and wires with good current ratings. Replace the original ESC connector, or extend the connecting wire to make adjustments to avoid poor connector contact, melting due to overheating, and abnormal power cutoff.
- Connect the battery just before driving and disconnect it after driving. Also, do not solder the battery directly to ESC, use the appropriate connector in between.
- Always connect a power source with the correct voltage and polarity to the ESC. Using power sources with different voltages or polarities can damage the ESC. Also, do not solder the ESC wire directly to the battery, be sure to use a connector in between.

ESC Setting ※ For experts

LED display: [Red] Selection of setting mode [Yellow] Selection of mode parameters

Detailed settings: (● number of blinks ● = 1 time ●● = 2 times ●●● = 3 times ●●●● = 4 times)

Setting mode (Red)			
Mode LED	Number of blinks	Setting mode (red)	Select Mode Parameter
Red	●	Reverse power	OFF LO MI HI
Red	●●	Start power	Proportional from low speed to high speed
Red	●●●	Drag brake	Proportional from low speed to high speed
Red	●●●●	Battery type	Auto Ni-cd/Ni-MH Li-Po Li-Fe

Mode Parameter (Yellow)				
	●	●●	●●●	●●●●
Reverse Power	OFF	LO	MI	HI ※
Start Power	Standard ※	LO	MI	HI
Drag Brake	OFF ※	LO	MI	HI
Battery Type	AUTO	Ni-cd / Ni-MH ※	Li-Po 7.4V	Li-Fe

※ = default value

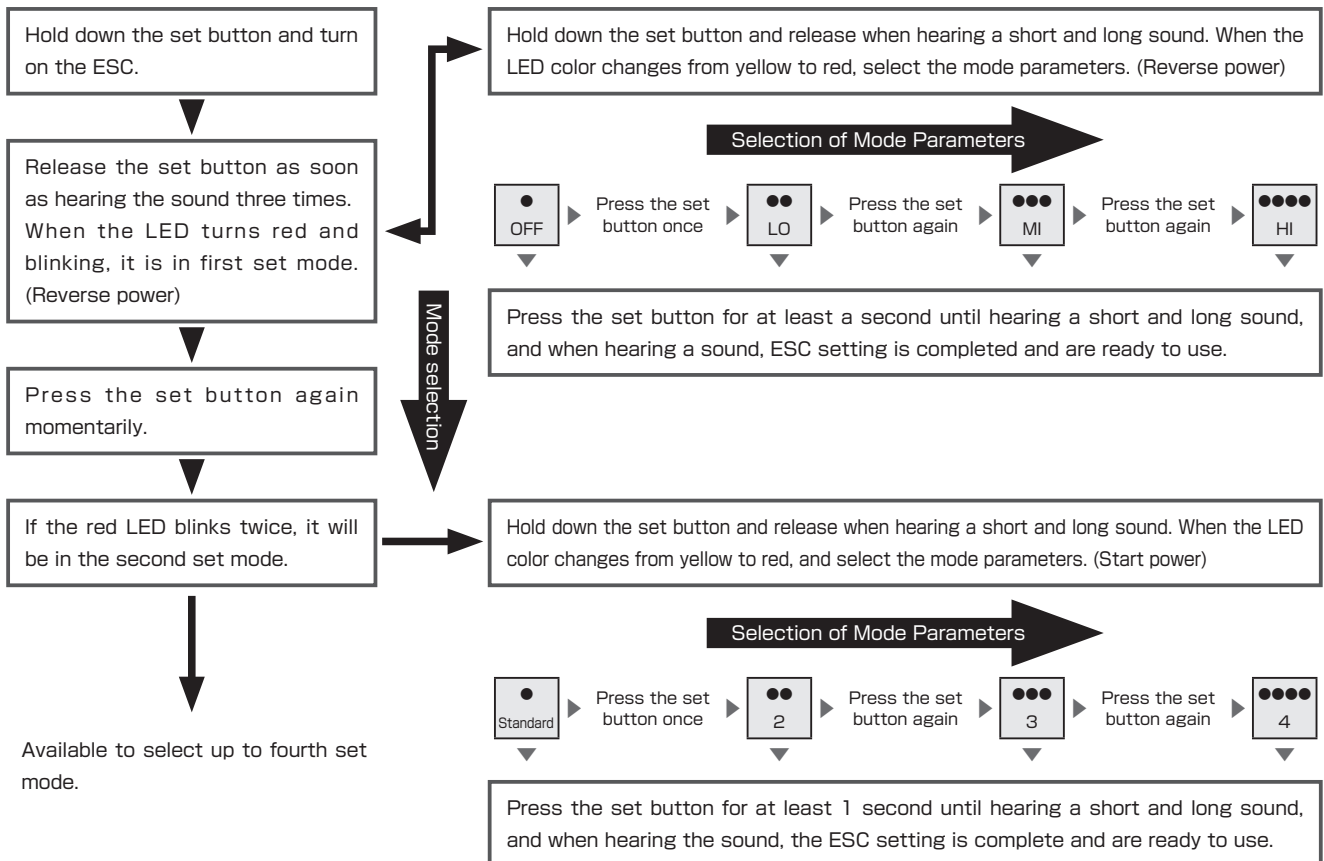

The above instructed LEDs are built into ESC. The other LEDs installed in ESC only lights up in red.

PARTS LIST

YD-2E SERIES

Item No.	Item Name	Quantity	Price	
				YD-2E PLUS
Kits				
DP-YD2E	Drift Package YD-2E		¥19,800	
DP-YD2EG	Drift Package YD-2EG		¥23,500	
DP-YD2EPLS	Drift Package YD-2E Plus Kit (Matt Graphite Specifications)		¥38,800	

Conversions

Y2-GC1	Grade Up Conversion 1 for YD2		¥7,800	★ ★
Y2-GC2	Grade Up Conversion 2 for YD2		¥6,980	★ ★

Rear A arm Suspension Kit

Y2-RAC3	Top Shaft of Y2-RAC for YD-2/EX/PLS	1	¥1,380	★ ★
Y2-RAC4	Spur Gear Hub of Y2-RAC for YD-2/EX/PLS	1	¥1,300	★ ★
Y2-RAC5	Upper Aarm Pin of Y2-RAC for YD-2/EX/PLS		¥300	★ ★
Y2-RAC6	Rear Sus Mount of Y2-RAC for YD-2/EX/PLS	1	¥1,680	★ ★
Y2-RAC7	Shockend Ball of Y2-RAC for YD-2/EX/PLS		¥200	★ ★
Y2-RAC8	R Shock Tower of Y2-RAC for YD-2/EX/PLS		¥5,800	★ ★

Steering Gyro

YG-302	Steering Gyro for Use with 3ch Radio		¥4,300	※ ★
DPP-302V4	ST Gyro[Black]w/EP Adj.for Use w/2-3ch		¥6,480	★ ★

Chassis Parts

Y2-001B	Alum.Front Bumper Brace for YD2/YD4	1	¥2,800	★ ★
Y4-001	Front Plastic Bumper for YD2/YD4		¥400	● ●
Y4-001F	Foam Front Bumper for YD2/YD4	1	¥480	● ●
SD-BW	Bumper Weight, 10g	5	¥780	★ ★
Y2-001R	Wide/Narrow Diffuser for DP-YD2		¥1,200	● ●
Y2-001RA	Wide/Narrow Diffuser for YD-2series		¥1,200	★ ★
Y4-001R	Wide/Narrow Diffuser for DP-YD4		¥1,200	★ ★
SD-001R	Rear Bumper	1	¥250	★ ★
Y2-002MG	Mat Graphite Main Chassis for YD2/EX/PLS	1	¥10,800	★ ●
Y2-002	Main Chassis(Mold) for DP-YD2	1	¥3,500	● ★
ZC-002P	Chassis Protective Sheet w/Yokomo Logo	1	¥980	★ ★
Y2-003MG	Mat Graphite Upper Deck for YD-2/PLS	1	¥2,160	★ ●
Y2-003	Upper Deck(Mold) for DP-YD2	1	¥850	● ★
Y2-302A	Chamfered Front Bulk Head A for YD-2		¥5,300	★ ★
Y2-302B	Chamfered Front Bulk Head B for YD-2		¥4,500	★ ★
Y2-302AM	Chamfered Upper Arm Holder for YD-2	1	¥1,800	★ ★
Y2-302AB	Front Bulk Head Brace for YD-2/EX1/PLS	1	¥980	★ ★
Y2-302MR	Front Bulk Head/Upper Arm Holder for YD2		¥750	● ●
Y2-303AR	Chamfered Rear Brace Support for YD-2	1	¥2,200	★ ★
Y2-303RB	Chamfered Rear Brace w/o Fan for YD-2	1	¥2,500	★ ★
Y2-303RBF	Chamfered Rear Brace w/Fan for YD-2	1	¥3,900	★ ★
Y2-303MR	Upper Deck Mount/R Brace Support for YD2		¥650	● ●
Y4-016	Front/Rear Body Mount for YD2/YD4		¥540	● ●
D-176	Black Multi Body Mount for Drift	2	¥680	★ ★
Y2-301	Sus_Mount/Hub/Servo Mount etc. for YD2		¥1,100	● ●
RC-313S	Small size Hood Pin (12pcs.)	12	¥120	● ●
RC-313SB	Small size Hood Pin Black(10pcs.)	10	¥200	★ ★
Y2-TSS	3mm Titanium Screw Set for YD-2/Plus		¥3,400	★ ★

Gear Diff.

Y2-500GS	Plastic Gear Diff. Assy. for YD-2/YZ-2	1	¥3,600	● ●
Y2-500GSA	MoldGear Diff.Assy.w/Alum.Dcup for YD-2	1	¥3,980	★ ★
B8-500DP	Drive Cup Protector for Alum.Drive Cup		¥360	★ ★
Y2-501GS2	DriveCup of GearDiff/Solid Axle/forYD-2	2	¥1,050	● ●
Y2-501GSA	AlumOut Drive Cup of Gear Diff for YD-2	2	¥1,200	★ ★
Y2-501GG	Gasket of Gear Diff. for YD-2/YZ-2	1	¥200	● ●
Y2-503GH	Gear Diff.Case/Cap for YD-2/YZ-2		¥700	● ●
Y2-503GP	Plastic Bevel Gear set for YD2/EX1/PLS		¥600	● ●
BD-500GA	Alm.Gear Diff shaft for BD7/5 B-MAX2/4	2	¥580	★ ★
CS-SLG	Seal Grease for O'ring/Gasket		¥860	★ ★

Solid Axle

Y2-502	Solid Axle Set for YD-2	1	¥3,000	★ ★
B8-500DP	Drive Cup Protector for Alum.Drive Cup		¥360	★ ★
Y2-501GS2	DriveCup of GearDiff/Solid Axle/forYD-2	2	¥1,050	● ●
Y2-501GSA	AlumOut Drive Cup of Gear Diff for YD-2	2	¥1,200	★ ★
Y2-501GG	Gasket of Gear Diff. for YD-2/YZ-2	1	¥200	● ●
Y2-503GH	Gear Diff.Case/Cap for YD-2/YZ-2		¥700	● ●

Ball Diff.

Y2-500	Ball Diff. Kit for YD-2		¥2,800	★ ★
B2-501MR	L/R Diff Outdrive Hub for B-MAX2MR/RS		¥1,300	★ ★
Z2-503	48p 52T Ball Diff.Gear for YZ-2CA/DT/4	1	¥400	★ ★
ZD-505	3/32 Precision Balls	24	¥150	★ ★
Z2-505T	3/32 Tungsten Carbide Ball(14pcs.)	14	¥1,120	★ ★
B2-506	Diff. Drive Ring	2	¥400	★ ★
ZS-507	Diff Thrust Washers/Diff Thrust Balls		¥200	★ ★
ZC-507T	1/16 Tungsten Carbide Ball(16 pcs.)		¥680	★ ★
BM-508	Diff. Adjustable Kit		¥280	★ ★
B2-508TS	Locking T nut/Thurst Spg.forYZ-2/4/MAX2		¥700	★ ★
BB-85-4	φ 5 x φ 8x2.5mm Ball Bearing (4 pcs.)	4	¥980	★ ★
BB-850P	φ 5X φ 8x2.5mm Super Prec.Bearing(2pcs)	2	¥980	★ ★
BB-850CB	φ 5x φ 8x2.5mm Ceramic Ball bearing(2pcs)	2	¥720	★ ★
CS-DG	Diff.Grease for Diff.Ball		¥1,000	★ ★
CS-HDL	Diff.Grease Hard type		¥480	★ ★

Drive Train

Y2-302	Trasmission Case for DP-YD2		¥850	● ●
Y2-303I	Idler Shaft for YD-2	1	¥200	● ●
Y2-303IA	Alum.Idler Shaft for YD-2	1	¥300	★ ★
Y2-303IG	Graphite Idler Shaft for YD-2	2	¥750	★ ★
Y2-304	Motor Mount for DP-YD2	1	¥1,500	● ●
Y2-304H	Special Motor Mount for DP-YD2	1	¥2,300	★ ★
Y2-503I	Idler Gear for YD-2	1	¥420	● ●
Y2-503IA	Alm.Idler Gear for YD-2	1	¥680	★ ★
Y4-630	Alum. Spur Gear Hub for YD-2/YD4	1	¥1,200	● ●
Y4-630C	Chamfered Spur Gear Hub for DP-YD4	1	¥1,950	★ ★
Y2-631	Alum.Top Shaft w/48P 20T Gear for DP-YD2	1	¥1,380	● ●

Universal Shaft & Axle

Y2-010FA	Alum.Front Axle for DP-YD2	2	¥800	★ ★
Y2-010F	Front Axle for DP-YD2	2	¥500	● ●
Y2-010FB	Low Friction Fr.Axle BB φ 5X φ 10(4pcs)	4	¥1,080	★ ★
Y2-010	Rear Univ.Drive Shaft(49mm)for DP-YD2	2	¥2,100	● ●
Y4-010	Universal Drive Shaft(47mm)for DP-YD4	2	¥2,100	★ ★
Y4-010A	Universal Axle for DP-YD2/YD4	1	¥500	● ●
Y4-010490	49mm Universal Bone for YD2/YD4	1	¥600	● ●
Y4-010B	Universal Bone for DP-YD4	1	¥600	★ ★
BD-010440	44.0mm Universal Bone for BD7/BD5	1	¥520	★ ★
BD-01440B	Alum.44.0mm Universal Bone for BD-7	1	¥900	★ ★
D-153B51	51.0mm Bone for Narrow ST block	1	¥520	★ ★
D-153B53	53.0mm Bone for Narrow ST block	1	¥520	★ ★
B8-500DP	Drive Cup Protector for Alum.Drive Cup		¥360	★ ★
Y4-010TP	Univ.Cup Joint for YD2/YD4 (Joint / φ 2pin / Set Screw)	1each	¥250	● ●

Wheel Hub

Y2-301	Sus_Mount/Hub/Servo Mount etc. for YD2		¥1,100	● ●
SD-011	Wheel Hub Pin & Nut(4 pcs each)	4	¥200	● ●
SD-011DC2	Chrome Plated Wheel Hub/License Plate		¥720	★ ★
SD-011DC3	Wheel Disc Hubs for A-arm		¥600	★ ★
Y2-011CB5	5.0mm Clamping Wheel Hub for YD-2	2	¥1,000	★ ★
Y2-011CB6	6.0mm Clamping Wheel Hub for YD-2	2	¥1,000	★ ★
Y2-011CB7	7.0mm Clamping Wheel Hub for YD-2	2	¥1,000	★ ★
Y2-011CB8	8.0mm Clamping Wheel Hub for YD-2	2	¥1,000	★ ★
ZS-011EL	Alum.Easy Wheel Hub for MR-4 series	2	¥780	★ ★
ZR-011SM	Rebuild Kit for EZ Wheel Hub	4	¥150	★ ★
B7-011NB	4.5mm Clamp Wheel Hub for BD716	2	¥1,180	★ ★
ZS-011TSB	Black Tread Adjust Spacer 0.5mm/1.0mm	4set	¥420	★ ★
ZS-011CM	Rebuild Kit for Cramping Wheel Hub		¥150	★ ★
ZS-011NM	Rebuild Kit for 4.5mmCramping Wheel Hub		¥240	★ ★
ZC-N4FBK	M4 Alum.Flange Serration Nut Black	4	¥380	★ ★
ZC-N4FBL	M4 Alum.Flange Serration Nut Blue	4	¥380	★ ★

Pinion and Spur gear

BM-4820	HARD STEEL PINION GEAR DP48-20T	1	¥420	● ●
SG-A4884	Precision 48 Pitch Spur Gear 84T	1	¥550	● ●

Steering linkage

ZC-204517	Alum.17mm Clamp Servo Horn (25T Spline)		¥1,380	★ ★
ZC-204520	Alum.20mm Clamp Servo Horn (25T Spline)		¥1,380	★ ★
ZC-204523	Alum.23mm Clamp Servo Horn (25T Spline)		¥1,480	★ ★
ZC-204317	Alum.26mm Clamp Servo Horn (23T Spline)		¥1,380	★ ★
ZC-204320	Alum.29mm Clamp Servo Horn (23T Spline)		¥1,380	★ ★
ZC-204323	Alum.32mm Clamp Servo Horn (23T Spline)		¥1,480	★ ★
Y4-201P	Alum.Bellcrank Post for DP-YD4	1	¥200	● ●

Y4-201PB	Brass Bellcrank Post for DP-YD2/4	1	¥250	★ ★
Y2-202V	Chamf.Variable ST Bell Crank Set YD-2		¥8,500	★ ★
Y2-202VH	Cen.Link Holder Variable ST Bellcrank	1	¥2,400	★ ★
Y2-202VCL	Cen.Link(Left)of Variable ST Bellcrank	1	¥1,300	★ ★
Y2-202VCR	Cen.Link(Right)of Variable ST Bellcrank	1	¥1,300	★ ★
Y2-202VL	Bellcrank(Left)of Variable ST Bellcrank	1	¥2,400	★ ★
Y2-202VR	Bellcrank(Right)of Variable ST Bellcrank	1	¥1,500	★ ★
Y2-202AB	Chamfered ST.Bell Crank Base for YD-2	1	¥1,100	★ ★
Y2-202AC	Chamfered ST.Bell Crank Right for YD-2	1	¥2,000	★ ★
Y2-202AL	Aluminum steering bell crank (L) for YD-2		¥2,100	★ ★
Y2-202AR	Aluminum steering bell crank (R) for YD-2		¥2,100	★ ★
Y2-202SC	Roundly Rack Stopper Cam for YD2E/S		¥900	★ ★
Y2-202B	Roundly Rack Base for YD2E/S		¥1,420	★ ★
Y2-202PC	Roundly Rack Stopper Pin for YD2E/S		¥680	★ ★
Y2-202RP	Roundly Rack Plate for YD2E/S		¥1,020	★ ★
Y2-202AP	Roundly Rack Arm Plate for YD2E/S		¥960	★ ★
Y2-202RR	Roundly Rack Rail for YD2E/S		¥2,180	★ ★
Y2-202BH	Roundly Rack Bulkhead(F L/R)for YD2E/S		¥4,200	★ ★
Y2-202BR	Roundly Rack Bulkhead(F Rear)for YD2E/S		¥2,080	★ ★
Y2-202SM	Roundly Rack Servo Mount for YD2E/S		¥1,980	★ ★
Y2-202UM	Roundly Rack U.arm Mount for YD2E/S		¥1,950	★ ★
Y2-202	Steeling Bell Crank Set for DP-YD2		¥850	● ●
IB-202KP	Center Link Pin for DIB	2	¥200	● ●
Y4-203A	Alum.Servo Mount for YD2/YD4	2	¥1,800	★ ★
ZC-206MH	Socket Head Ballstud M(12.8mm)size	6	¥480	● ●
Y4-207	Ball End Caps for YD2/YD4		¥780	● ●
Y2-301	Sus_Mount/Hub/Servo Mount etc. for YD2		¥1,100	● ●
D-125	Kingpin for Lower Caster Block		¥250	★ ★

Suspension

Y2-017AFE	Chamf.Fnt.Shock Adjuster for YD-2/EX1/PLS	1	¥3,900	★ ●
Y2-018AR2	Chamfered Rear Shock Tower for YD-2EX II	1	¥4,580	★ ★
Y2-017	Front/Rear Shock Tower(Mold)for DP-YD2		¥850	● ★
Y2-302A	Chamfered Front Bulk Head for YD-2		¥5,300	★ ★
Y2-302B	Chamfered Front Bulk Head for YD-2		¥4,500	★ ★
Y2-302AM	Chamfered Upper Arm Holder for YD-2	1	¥1,800	★ ★
Y2-008FLS	Front Short Lower A_arm for DP-YD2		¥620	● ●
D-154-15	F Lower A_arm Rod end adapter(15mm)	2	¥520	★ ★
D-154-18	F Lower A_arm Rod end adapter(18mm)	2	¥520	★ ★
D-154-21	F Lower A_arm Rod end adapter(21mm)	2	¥580	● ●
Y2-008FUC	Chamfered Front Upper A_arm for YD-2		¥3,800	★ ★
D-142	F.Upper A arm Rod end Adp.for Dri-pack	2	¥400	★ ★
D-155-20	F Upper A_arm Rod end adapter(20mm)	2	¥600	★ ★
D-155-23	F Upper A_arm Rod end adapter(23mm)	2	¥600	★ ★
Y2-008FU	Front Upper A_arm for DP-YD2		¥680	● ●
Y2-008RA	Adjustable Rear"H"Arm Kit for YD-2/4		¥8,600	★ ★
Y2-008RA1	Adjustable Rear"H"Arm(A)(L) for YD-2/4	1	¥2,480	★ ★
Y2-008RA2	Adjustable Rear"H"Arm(A)(R) for YD-2/4	1	¥2,480	★ ★
Y2-008RA3	Adjustable Rear"H"Arm(B)(L) for YD-2/4	1	¥1,900	★ ★
Y2-008RA4	Adjustable Rear"H"Arm(B)(R) for YD-2/4	1	¥1,900	★ ★
Y2-008RA5	0.5mm Spacer for Adjust.Rear"H"Arm		¥480	★ ★
Y2-008RA6	1.0mm Spacer for Adjust.Rear"H"Arm		¥480	★ ★
Y2-008RA7	2.0mm Spacer for Adjust.Rear"H"Arm		¥480	★ ★
Y4-008R	Rear Lower Sus_Arm for YD2/YD4		¥540	★ ★
Y2-008R	LS Rear Lower Sus_for DP-YD2/YD4		¥640	● ●
Y2-008RS	R Short Lower arm for YD-2EX II		¥680	★ ★
IB-414KBC	10mm Hex Kingpin Ball for Alm.ST Block	4	¥350	★ ★
IB-414KB1	11mm Hex Kingpin Ball for Alm.ST Block	4	¥430	★ ★
IB-414KB2	12mm Hex Kingpin Ball for Alm.ST Block	4	¥430	● ●
Y2-009A	Hinge Pin set for DP-YD2		¥780	● ●
Y2-009FA	Front Upper A_arm Pin for DP-YD2	2	¥300	● ●
BD-009A	Outer Sus. Arms Pins for BD-8/BD-7	4	¥300	● ●
BD-009BF	Front Inner Sus. Arms Pins for BD7/BD5		¥300	● ●
BD-009BR	Rear Inner Sus. Arms Pins for BD7/BD5	2	¥300	● ●
ZC-206AB	Alum.Sway Bar Ball(Black) for BD-7	2	¥320	★ ★
ZC-206SH	Socket Head Ballstud S(11.3mm)size L-N	6	¥480	● ●
ZC-206MH	Socket Head Ballstud M(12.8mm)size	6	¥480	● ●
ZC-206SHS	Socket Head Ballstud S(11.3mm) size S-N	6	¥480	● ●
Y2-RAC7	Shockend Ball of Y2-RAC for YD-2/EX/PLS		¥200	★ ★
Y4-207	Ball End Caps for YD2/YD4		¥780	● ●
Y2-301	Sus_Mount/Hub/Servo Mount etc. for YD2		¥1,100	● ●
Y2-301AC	Alum.Adjustable Sus_Mount Set forYD-2/4		¥7,400	★ ★
B8-301A	Alum.Sus.Mount(39.5 ~ 42.7mm)for BD-8/9	1	¥1,680	★ ★
B8-301B	Alum.Sus.Mount(43.5 ~ 46.7mm)for BD-8/9	1	¥1,680	★ ★
B8-301C	Alum.Sus.Mount(46.4 ~ 49.6mm)for BD-8/9	1	¥1,680	★ ★
Y2-301D2	Alum.Sus_Mount"D" for YD-2EX II	1	¥1,880	★ ★
Y2-301E2	Alum.Sus_Mount"E" for YD-2EX II	1	¥1,880	★ ★
B8-301BS	Sus.Mount Bushing for BD-8	1	¥700	★ ★
BD-301B	3 φ Sus. Arm Pin Ball for BD7/BD5	4	¥250	● ●

Y2-301S	1.0mm Sus-mount spacers for YD-2	2	¥500	★ ★
Y2-302MD	SusMount/F.Bulk/U.Arm Hold forYD2S/S-PL		¥980	● ●
Y2-415S2	Steering Block Ver.2 for YD2		¥580	★ ★
Y2-415SA	Adjustable Kingpin Angle ST Block for YD		¥5,900	★ ★
Y2-415SA1	ST Block Base of Y2-415SV for YD-2sers.		¥4,700	★ ★
Y2-415SA2	ST Block Adp.of Y2-415SV for YD-2sers.	1	¥650	★ ★
Y2-415SA3	ST Block Weight.ofY2-415SV for YD-2sers.		¥1,580	★ ★
Y2-415SA4	ST Block φ 4 Pin ofY2-415SV forYD-2sers.	2	¥380	★ ★
Y2-415SA5	ST Block φ 5 Pin ofY2-415SV forYD-2sers.	2	¥380	★ ★
Y2-415SA6	ST Block 0.5mm Spacer of Y2-415SV	2	¥750	★ ★
Y2-415SA7	ST Block 1.0mm Spacer of Y2-415SV	2	¥750	★ ★
Y2-415AR	Chamfered Rear Hub Carrier for YD-2		¥4,100	★ ★
Y2-415R	Rear Hub Carrier for DP-YD2		¥580	● ●

Shock Absorber

Y2-SBBS	SLF Big Bore Shock set for DP-YD2		¥6,900	★ ●
B7-S113	φ 1.1 x 3Holes Piston for SLF Short II	4	¥480	★ ★
B7-S114	φ 1.1 x 4Holes Piston for SLF Short II	4	¥480	★ ●
B7-S2B	P3 O_ring Coller(Thick)for SLF short II	4	¥450	★ ●
B7-S3N	Normal Spring Cup for BD-7	2	¥650	★ ●
B7-S3S16	Short Spring Cup for BD7-2016	2	¥680	★ ●
Y4-S4	SLF Shock Cylinder for Big Bore shock	2	¥1,600	★ ●
Y4-S4C	O Ring Cap/Ajust Nut/Capnut for BigBore	2each	¥1,350	★ ●
Y4-S5	SLF Shock Shaft for Big Bore	1	¥200	★ ●
Y4-S5T	SLF Ti-Coated Shaft for Big Bore	4	¥1,700	★ ★
Y4-S6	Shock Cap/Shock End for Big Bore Shock		¥650	★ ●
Y4-S8	Shock Mounting Ball(4 pcs.)for Big Bore	4	¥650	★ ●
B7-8DS16	Silicon Rubber Diaphragm for Short II	4	¥350	★ ●
B7-8DF16	Fluorine Rubber Diaphragm for Short II	4	¥420	★ ★
YS-S4AJM	Oring Cap/AJ.Nut for 4pcs.Pla_shock	4set	¥740	● ★
YS-S4CM	Molded Shock Cap Nut for 4pcs.Pla_shock	4	¥600	★ ★
YS-S4M	Shock Cylinder for 4pcs.Pla_shock	4	¥700	● ★
YS-5SSS-1	SSS Size Shock Shafts	1	¥200	● ★
YS-53S-1T	Titanium Shock Shafts	1	¥420	★ ★
YS-S6M	ShockCap End/ShockEnd for 4pcs.Pla_shock	4set	¥700	● ★
YS-7B	Down Stop "O" Ring for Shock (8pcs.)	8	¥120	● ★
YS-7S	Soft"O"ring for Shock(8pcs.)	8	¥120	● ●
YS-7HG	High Grade Blue P3 O Ring Blue 8 pcs	8	¥380	★ ★
Y4-8B	13.5mm Shock Cap Ball(4pcs.)for YD2/YD4	4	¥350	● ★
YS-8DMH	Hard Silicon Rubber Diaphragm	4	¥350	★ ★
YS-8HD	Fluorine Rubber Hyper Diaphragm	4	¥380	★ ★
YS-S9M	Piston/Spring Cup for 4pcs.Pla_shock	4	¥740	● ★
Y2-301	Sus_Mount/Hub/Servo Mount etc. for YD2		¥1,100	★ ●
ZC-206SHS	Socket Head Ballstud S(11.3mm)size S-N	6	¥480	● ●
Y2-RAC7	Shockend Ball of Y2-RAC for YD-2/EX/PLS		¥200	★ ★
ZC-A3625B	Alm.Shim φ 3x φ 6x2.5mm Black	8	¥420	★ ★

Spring

D-1190	Super drift spring orange	2	¥420	★ ★
D-119Y	Super drift spring yellow	2	¥420	★ ★
D-119BK	Super drift spring black	2	¥420	★ ★
D-170G	φ 1.3x 9.5T Green Reg.Pitch for Drift	2	¥580	● ●
D-170P	φ 1.2x10.5T Pink Reg.Pitch for Drift	2	¥580	● ●
D-170BK	φ 1.1x 9.5T Black Reg.Pitch for Drift	2	¥580	★ ★
D-170BL	φ 1.1x10.5T Blue Reg.Pitch for Drift	2	¥580	★ ★
D-171G	φ 1.3x9.5T Green Var.Pitch for Drift	2	¥580	★ ★
D-171Y	φ 1.2x9.5T Yellow Var.Pitch for Drift	2	¥580	★ ★
D-171P	φ 1.2x10.5T Pink Var.Pitch for Drift	2	¥580	★ ★
YS-1480	HSS Long Shock Springs ORANGE	2	¥420	★ ★
YS-1380	HSS Long Shock Springs Green	2	¥420	★ ★
YS-1280	HSS Long Shock Springs Pink	2	¥420	★ ★
YS-1290	HSS Long Shock Springs Yellow	2	¥420	★ ★
YS-1190	HSS Long Shock Springs BLACK	2	¥420	★ ★

Turnbuckle

SD-TB16	Hard Steel 16mm Turnbuckle	2	¥300	● ●
SD-TB25	Hard Steel 25mm Turnbuckle	2	¥300	★ ★
SD-TB27	Hard Steel 27mm Turnbuckle	2	¥300	● ●
SD-TB30	Hard Steel 30mm Turnbuckle	2	¥300	● ●
SD-TB33	Hard Steel 33mm Turnbuckle	2	¥300	● ●
SD-TBL	Turnbuckle Wrench for Drift Car	1	¥200	● ●
ZC-TB16B	Titanium Turnbuckles, 16mm	2	¥800	★ ★
ZC-TB25B	Titanium Turnbuckles, 25mm	2	¥800	★ ★
ZC-TB27B	Titanium Turnbuckles, 27mm	2	¥860	★ ★
ZC-TB30B	Titanium Turnbuckles, 30mm	2	¥860	★ ★
ZC-TB33B	Titanium Turnbuckles, 33mm	2	¥980	★ ★
KLD-W	Alum.Turn Buckle Wrench for Lunsford	1	¥300	★ ★
Y2-TBSA	Titanium Turnbacle Set for YD-2/YD-2PLS		¥3,200	★ ★

Ball Bearing

Y2-010FB	Low Friction Fr.Axle BB φ 5X φ 10(4pcs)	4	¥1,080	★ ★
BB-84-2	φ 4 x φ 8x3mm Ball Bearing (2 pcs.)	2	¥400	● ●
BB-84-4	φ 4 x φ 8x3mm Ball Bearing (4 pcs.)	4	¥800	● ●
BB-105-2	φ 5 x φ 10x4mm Ball Bearing (2 pcs.)	2	¥450	● ●
BB-1510	φ 10x φ 15x4mm Ball Bearing (2 pcs.)	2	¥600	● ●
BB-840P	φ 4X φ 8x3mm Super Prec.Bearing(2pcs)	2	¥980	★ ★
BB-1050P	φ 5X φ 10x4mm Super Prec.Bearing(2pcs)	2	¥980	★ ★
BB-1510P	φ 10X φ 15x4mm Super Prec.Bearing(2pcs)	2	¥980	★ ★
BB-1050CB	φ 5x φ 10x4mm Ceramic Ball bearing(2pcs)	2	¥1,000	★ ★
BB-1510CB	φ 10x φ 15x4mm Ceramic Ball bearing(2pcs)	2	¥1,200	★ ★
D-132	4X8 Ball Bearing,unflanged Teflon sealed	2	¥500	★ ★

Spacer & Shims

ZC-A2505	Blue φ 2.5x φ 5x0.5mm Shim	8	¥420	★ ★
ZC-A2510	Blue φ 2.5x φ 5x1.0mm Shim	8	¥420	★ ★
ZC-A2520	Blue φ 2.5x φ 5x2.0mm Shim	8	¥420	★ ★
ZC-A3605B	Alm.Shim φ 3x φ 6x0.5mm Black	8	¥420	★ ★
ZC-A3610B	Alm.Shim φ 3x φ 6x1.0mm Black	8	¥420	★ ★
ZC-A3620B	Alm.Shim φ 3x φ 6x2.0mm Black	8	¥420	★ ★
ZC-A3625B	Alm.Shim φ 3x φ 6x2.5mm Black	8	¥420	★ ★
ZC-A3630B	Alm.Shim φ 3x φ 6x3.0mm Black	8	¥420	★ ★

Screws, Nut and Washer

ZC-BH24TP	M2x4.0mm Tapping screw	8	¥120	● ●
ZC-TP25	2 φ X5mm Screws	10	¥100	● ●
ZC-BH28TP	M2x8.0mm BH Tapping screw	8	¥280	● ●
ZC-BH254	M2.5X4 Button Head Socket Screw	8	¥250	★ ★
ZC-BH35	M3X5 Button Head Socket Screw	10	¥150	● ●
ZC-BH36	M3X6 Button Head Socket Screw	10	¥150	● ●
ZC-BH38	M3X8 Button Head Socket Screw	10	¥150	● ●
ZC-BH310	M3X10 Button Head Socket Screw	10	¥150	● ●
ZC-BH312	M3X12 Button Head Socket Screw	10	¥150	● ●
ZC-BH335	M3X35 Button Head Socket Screw	4	¥150	● ●
ZC-BH35T	M3X5 Titanium Butt.Head Socket Screw	5	¥350	★ ★
ZC-BH36T	M3X6 Titanium Butt.Head Socket Screw	5	¥350	★ ★
ZC-BH38T	M3X8 Titanium Butt.Head Socket Screw	5	¥350	★ ★
ZC-BH310T	M3X10 Titanium Butt.Head Socket Screw	5	¥350	★ ★
ZC-BH312T	M3X12 Titanium Butt.Head Socket Screw	4	¥350	★ ★
ZC-BH335T	M3X15 Titanium Butt.Head Socket Screw	2	¥380	★ ★
ZC-F38T	M3X8 Flathead Socket Screw	10	¥150	● ●
ZC-F310	M3X10 Flathead Socket Screw	10	¥150	● ●
ZC-F312	M3X12 Flathead Socket Screw	10	¥150	● ●
ZC-F315	M3X15 Flathead Socket Screw	10	¥150	● ●
ZC-F318	M3X18 Flathead Socket Screw	8	¥150	● ●
ZC-F38T	M3X8 Titanium Flathead Socket Screw	5	¥350	★ ★
ZC-F310T	M3X10 Titanium Flathead Socket Screw		¥350	★ ★
ZC-F312T	M3X12 Titanium Flathead Socket Screw		¥350	★ ★
ZC-F315T	M3X15 Titanium Flathead Socket Screw		¥350	★ ★
ZC-F318T	M3X18 Titanium Flathead Socket Screw		¥380	★ ★
Y2-TSS	3mm Titanium Screw Set for YD-2/Plus		¥3,400	★ ★
ZC-SS34	M 3 X 4 Set Screws	10	¥120	● ●
ZC-SS36	M 3 X 6 Set Screws	10	¥120	● ●
ZC-SS315	M 3 X 15 Set Screws	10	¥120	● ●
ZC-S36	3 X 6 X 0.5mm Steel Washer	10	¥100	● ●
ZC-S37	Link Mount Spacer TYPE-C	10	¥100	● ●
ZC-N3P	M3 PLane Nut(2.4mmthick)	10	¥100	● ●
ZC-N3APBA	3mm Plane Nuts	4	¥160	★ ★
ZC-N4FBK	4mm Alum.Flange Nylon Rock Nuts(Black)	4	¥380	★ ★

Tools and gauges

YT-300	Cross Wrench 5mm/5.5mm/7.0mm/End	1	¥200	● ●
SD-TBL	Turnbuckle Wrench for Drift Car	1	¥200	● ●
KLD-W	Alum.Turn Buckle Wrench	1	¥300	★ ★
YT-DP1W	Works Wrench #1 Screw Driver	1	¥1,200	★ ★
YT-N55W	Works Wrench 5.5mm Nut Driver	1	¥1,520	★ ★
YT-N70W	Works Wrench 7.0mm Nut Driver	1	¥1,520	★ ★
YT-SR3W	Works Wrench 3.0mm Straight Reamer	1	¥1,360	★ ★
YT-BMRW	Works Wrench Mounting Hole Reamer	1	¥3,300	★ ★
YT-15WB	Works Wrench 1.5mm Replacement Tip	1	¥480	★ ★
YT-20WB	Works Wrench 2.0mm Replacement Tip	1	¥480	★ ★
YT-CGP	Camber Gauge Pro Black	1	¥1,280	★ ★
YT-CGPB	Camber Gauge Pro Blue	1	¥1,280	★ ★
YT-STBM3	Yokomo Setting Board M III	1	¥3,800	★ ★
YT-25PB4	Yokomo Racing Pit Bag IV	1	¥16,800	★ ★

Others

ZR-200G	Black Antenna Tube for 2.4GHz RX	2	¥100	● ●
ZR-BMP5	φ 5x0.5mm thick Body Mount Patch	8	¥360	★ ★
YT-RWF5	Steel Racing Weight (5g x 10pcs.)	10	¥300	★ ★
YT-2BK	12mm X 50m Black Strapping Tape		¥950	★ ★
ZC-203	Servo Mounting Tape, 2pcs		¥90	● ●
ZC-203B	Black Servo Mounting Tape	3	¥250	★ ★
D-013	Drift Oil		¥980	★ ★
CS-HDL	Diff.Grease Hard type		¥720	★ ★
CS-DG	Diff.Grease for Diff.Ball		¥480	★ ★
CS-BG	Yokomo Super Black Grease		¥480	★ ★
RP-031	30 mm Cooling Fan	1	¥980	★ ★
RP-032	40 mm Cooling Fan	1	¥980	★ ★
RP-033	Hyper Cooling Fan for Motor	1	¥1,580	★ ★
ZC-002P	Chassis Protective Sheet w/Yokomo Logo	1	¥980	★ ★
ZC-D15R	Yokomo Decals, Red	1	¥480	★ ★
ZC-D16	Yokomo Logo Decal	1	¥1,480	★ ★

"● ★" in the parts list is the compatibility notation of the kit.

● = Standard ★ = Option

○ = The standard equipment contents differ depending on the specifications of the kit.

※ The product name in this parts list may differ from the actual product name.